

ZOOMLION

FD80-100Z

INTERNAL COMBUSTION FORKLIFT



■ The color combination has obtained the protection of registered trademark

◆ **More Reliable**

- Self-made frame, high-precision welding of robotic arms, more sturdy and durable;
- The cooling system has been optimized and designed, and the inter cooling, water cooling and oil cooling are independently arranged. Greatly improve the reliability of the core components of the engine and gearbox;
- The high-pressure hose is sealed with a 24° cone to prevent leakage;
- The hydraulic system is equipped with explosion-proof valve to ensure safe operation and reliable work;
- Panoramic rear-view mirrors provide a wider rear-view field for safer driving;
- The neutral start protection function can effectively prevent mis-operation.



● 24 degree cone seal

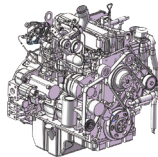

● Cummins F3.8

◆ **More comfortable**

- Spacious upper and lower pedals and driving space, reducing leg manipulation fatigue;
- Manipulating the valve stem is ergonomic.



▲ Spacious driving space

FEATURES

▼ **High precision welding of manipulator**

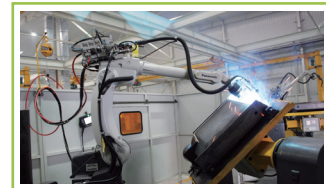

◆ **More efficient**

- The streamlined design of the whole vehicle has a beautiful appearance, and has the advantages of stable working conditions, high working efficiency, high power, and good climbing performance, which can be operated in harsh working conditions;
- The hydraulic system adopts dual-pump confluence technology, which improves the work efficiency;
- Equipped with CAN technology, the driver can know the state of the engine in real time through the instrument;
- Hydraulic reversing gearbox + 315M high-capacity torque converter, the performance is more stable and reliable;
- It adopts a large air filter with a safety filter element and is equipped with a pre-filter to ensure the intake air volume of the engine.

◆ **More environmentally**

- Built in thermal insulation and sound-absorbing materials and rubber seals to greatly reduce vibration and noise;
- The engine meets the emission requirements of national III.

ZOOMLION FD80-100Z

Features		FD80Z	FD100Z
Power	-	Diesel	Diesel
Rated Capacity	Q(lb)	17637	22046
Center of load	c(in)	23.6	23.6
Lifting height	h3(in)	118	118
Free lifting height	h2(in)	7	8.66
Forks LxWxH	s/e/l(in)	48x5.91x2.95	48x6.9x3.15
Tilt Forward/Backward	°	6/12	6/12
Min.turning radius	Wa(in)	143.8	160.6
Min.ground clearance(Mast)	Ra(in)	230.8	260.6
ground clearance(Mast)	m1(in)	12	8.86
Overhead guard height	h6(in)	99.6	102.36
Front overhang	x(in)	26.8	28.3
Performance			
Max.traveling speed(empty)	mile/h	16.2/18.6	12.4/15.5
Max.lifting speed(loaded/empty)	in/s	18.11/19	11.22/10.6
Gradeability	%	28	20
Size			
Overall length (without fork)	L1(in)	146.3	167.7
Overall width	b1/b2(in)	80	87.8
Mast lowered height	h1(in)	103.54	112.2
Mast extended height	h4(in)	172.24	168.5
Chassis			
Tire Front	-	8.25-20-14PR	9.00-20-14PR
Tire Rear	-	8.25-15-14PR	9.00-20-14PR
Wheelbase	y(in)	92.13	110.24
Tread width(Front/Rear)	b10/11(in)	57.87/67	63/67
Curb weight(Non-load)	lb	22818	27888
Engine			
Battery(Voltage/Capacity)	V/Ah	(12/90)x2	(12/90)x2
Engine type	-	Cummins F3.8	Cummins F3.8
Rated power	kW	90	90
Rated torque	lbf-ft	368.78	368.78
Displacement	L	3.8	3.8

The company reserves the right to modify the parameters provided. In case of material commercial modification information, the following notice shall prevail.

Capacity Chart

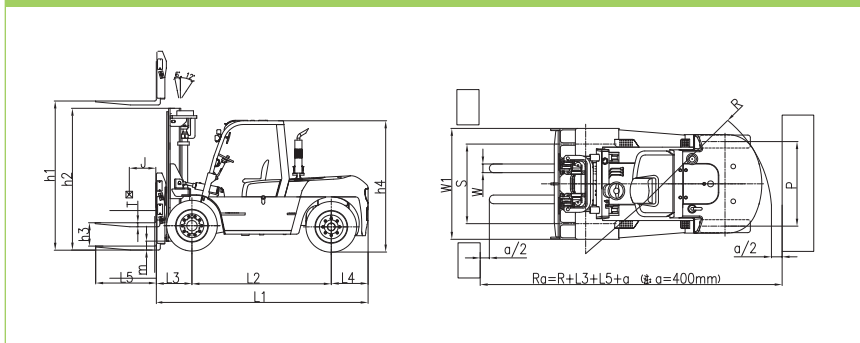

Machine 2D Graph

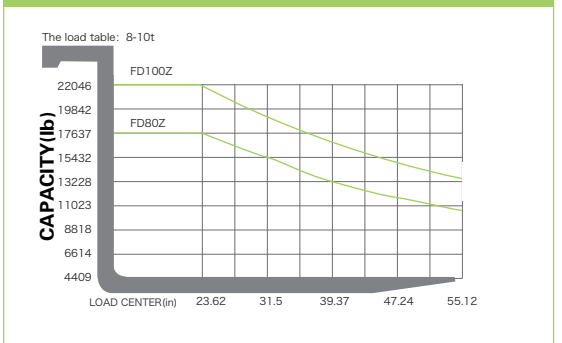

THUBAS TUNGGAL PERKASA
Make it Better | Your Solutions | Customer is Our Goal

Gang Wates Kp. Rawa Banteng No.83 Rt 003/01 Ds Mekarwangi
Kec. Cikarang Barat, Kabupaten Bekasi, Jawa Barat