

FD50/60/70Z

内燃平衡重式叉车
DIESEL FORKLIFT

Doc+or
FORKLIFT



ZOOMLION



Pergudangan Lautan Jaya Kumala, Jl. Inspeksi Kalimalang KM. 22 Blok A
Gudang A-01, Cibuntu, Bekasi-17520

Telp : (021) 89535873
Mobile : 0817-0555-969
Email : thubastunggalperkasa@gmail.com
Website : www.thubastunggalperkasa.co.id

内燃平衡重式叉车 DIESEL FORKLIFT



主配发动机扭矩大、功率大、动力强劲，可满足不同工作需求；
Engine is with large torque and capacity, which is powerful and can meet different operation demands;



整车整体式护顶架，顶棚为一次性冲压成型件，装有5个透明塑料罩，具有良好的采光和防雨效果；
Integrated overhead guard is adopted. The canopy is one time stamping part with 5 pieces transparent plastic cover, which receives sufficient light and keeps rain out;



液压系统加装了防爆阀，确保操作安全，工作可靠；
Hydraulic system is equipped with the throttling valve, which makes operation safe and reliable;



加强型宽视野门架，提高了工作效率和操作安全性；
Reinforce mast with wide view design improves efficiency and safety meanwhile enhances anti-forde capacity;



科学的人机工程设计，整车操纵更轻便、更舒适，座椅前后方向及靠背的角度可调；
Scientific ergonomic design makes more portable and comfortable. Seat and backrest are adjustable;



方向盘倾角可调，腿部空间大，精巧方便的换挡机构具有换挡迅速和操作简便的性能。
Steering wheel tilt angle is also adjustable, which leaves more legroom. The portable gearshift is quick to shift and easy to operate;

ZOOMLION

整机参数 (Machine Parameters)

特性	Features		FD50Z	FD60Z	FD70Z
动力形式	Power	—	柴油	柴油	柴油
额定载荷	Rated Capacity	kg	5000	6000	7000
载荷中心距	Center of load	J(mm)	600	600	600
最大起升高度	Lifting height	h1(mm)	3000	3000	3000
自由起升高度	Free lifting height	h3(mm)	203	208	218
货叉尺寸 长×宽×厚	Forks L×W×H	L5×W×T(mm)	1220×150×55	1220×150×60	1220×150×70
门架倾角 前/后	Tilt Forward/Backward	-	6/12	6/12	6/12
最小转弯半径	Min.turning radius	R1(mm)	3320/3415(锡柴 6110)	3420/3507 (锡柴6110)	3420/3507(锡柴 6110)
最小直角堆垛宽度	Min right angle stalking width	Ra(mm)	5550/5645(锡柴 6110)	5655/5742 (锡柴6110)	5665/5752(锡柴 6110)
最小离地间隙 (门架)	Min.ground clearance(Mast)	m(mm)	200	200	200
护顶架高度	Overhead guard height	h4(mm)	2460	2460	2460
前悬距	Front overhang	L3(mm)	610	615	625
后悬距	Rear overhang	L4(mm)	566	692	692
性能 Performance					
最大行驶速度 (满载)	Max.traveling speed(loaded)	km/h	26	26	26
最大起升速度 (满载/空载)	Max.lifting speed(loaded/empty)	mm/s	370/450	370/450	350/450
最大牵引力/满载爬坡能力	Drawbar pull/Gradeability	kN/%	51.4/20	51.4/20	51.4/20
尺寸 Size					
全长 (有货叉)	Overall length with fork	L1(mm)	4646 /4736(锡柴 6110)	4677//4767 (锡柴6110)	4687/4777(锡柴 6110)
全宽	Overall width	W1(mm)	2000	2000	2000
门架高度	Mast lowered height	h2(mm)	4417	4417	4417
作业时最大高度	Max extended height	mm	2500	2500	2500
底盘 Chassis					
轮胎 (前轮)	Tire(Front)	—	8.25-15-14PR	8.25-15-14PR	8.25-15-14PR
轮胎 (后轮)	Tire(Rear)	—	8.25-15-14PR	8.25-15-14PR	8.25-15-14PR
轴距	Wheelbase	L2(mm)	2250/2340 (锡柴 6110)	2250/2340 (锡柴6110)	2250/2340 (锡柴 6110)
轮距 (前轮/后轮)	Tread width(Front/Rear)	S/P(mm)	1470/1700	1470/1700	1470/1700
自重 (无载荷)	Curb weight(Non-load)	kg	7980	8640	9340
驱动 Engine					
蓄电池(电压/容量)	Battery(Voltage/Capacity)	V/Ah	(12/90)×2	(12/90)×2	(12/90)×2
发动机型号	Engine type	—	锡柴 CA4DF3	锡柴 CA4DF3	锡柴 CA4DF3
额定功率	Rated power	kw	85/2200	85/2200	85/2200
额定扭矩	Rated torque	kw	460/1400-1500	460/1400-1500	460/1400-1500
排量	Displacement	L	4.75	4.75	4.75

ZOOMLION

M 宽视野基本型门架 (2-Stage Standard Mast) / Z 两节全自由门架 (2-Stage Full Free Mast)

起升高度 Lifting height	承载能力 Coading capacity			门架高度 Mast lowered height		自由起升高度带挡货架 Free lifting height with backrest			门架倾角 Masttilt Angle f/r
	5T	6T	7T	货叉落地 mm	货叉起升 mm	5T mm	6T mm	7T mm	
3000	5000	6000	7000	2500 *2560	4417 *4426	203 *1189	208 *1193	218 *1204	6/12
3500	5000	6000	7000	2750 *2810	4917 *4926	203 *1439	208 *1443	218 *1454	6/12
4000	5000	6000	6800	3050 *3110	5417 *5426	203 *1739	208 *1743	218 *1754	6/12
4500	4800	5800	6600	3300 *3360	5917 *5926	203 *1989	208 *1993	218 *2004	6/6
5000	4600	5500	6300	3550 *3610	6417 *6426	203 *2239	208 *2243	218 *2254	6/6
5500	4500	5400	6200	3850 *3910	6917 *6926	203 *2539	208 *2543	218 *2554	3/6
6000	4400	5200	6000	4100 *4160	7417 *7426	203 *2789	208 *2793	218 *2804	3/6

注: 1.*为二节全自由门架参数;
2.不带挡货架的自由提升高度(二节全自由):5T-6T +410mm,7T+ 247mm;
3.货叉起升门架高度:标准 5-6T -420mm,7T -299mm,二节全自由门架:5-6T -410mm,7T -280mm.

S 三节全自由门架 (3-Stage Full Free Mast)

起升高度 Lifting height	承载能力 Coading capacity			门架高度 Mast lowered height		自由起升高度带挡货架 Free lifting height with backrest			门架倾角 Masttilt Angle f/r
	5T	6T	7T	货叉落地 mm	货叉起升 mm	5T mm	6T mm	7T mm	
4000	4800	5800	6800	2475	5420	1104	1108	1118	6/6
4350	4500	5500	6500	2590	5767	1219	1223	1233	6/6
4800	4500	5500	6500	2740	6217	1369	1373	1383	6/6
5000	4500	5500	6500	2805	6410	1434	1438	1448	6/6
6000	4000	5000	6000	3190	7410	1819	1823	1833	3/6

注: 1.不带挡货架的自由提升高度:5T-6T +433mm,7T+ 236mm;
2.货叉起升门架高度:标准 5-6T -331mm,7T -263mm.

载荷曲线图 (Capacity Chart)

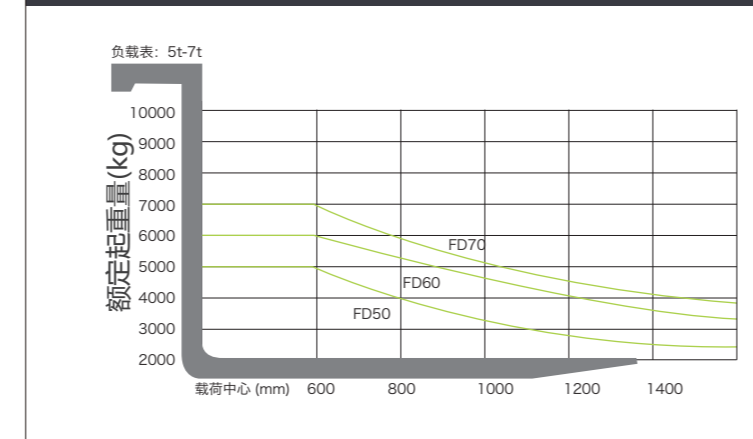

整机二维图 (Machine 2D Graph)

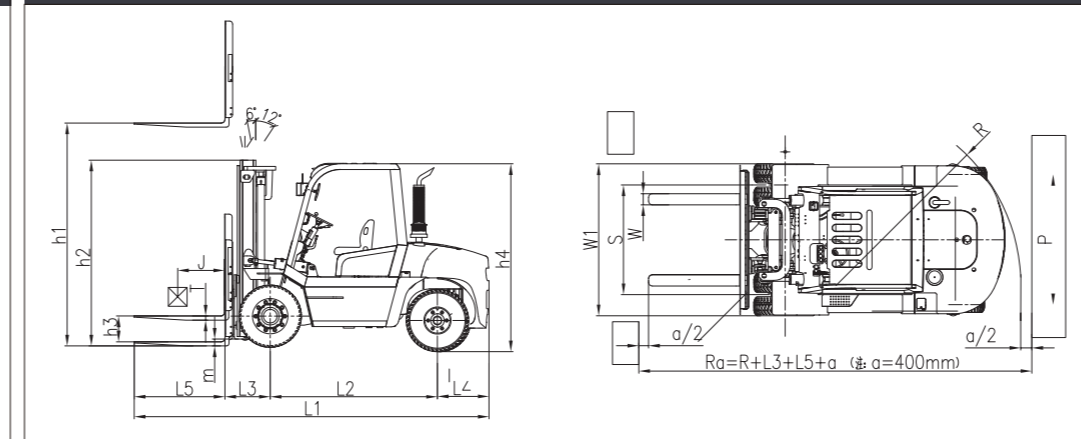

ZOOMLION

标准装备 (Standard Equipment)

● 宽视野门架	Wideview mast	● 计时表	Timer	● 液压回油滤芯	Hydraulic oil return filter
● 标准货叉	Standard fork	● 拉索式停车制动	Parking brake	● 液压吸油滤芯	Hydraulic oil intake filter
● 标准座椅	Standard seat	● 升降倾斜操纵杆	Lifting & tilting handle	● 液压油标尺	Hydraulic oil level gauge
● 挡货架	Backrest	● 起升油路限速阀	Speed limit valve	● 油压报警	Oil pressure indicator
● 倒车灯	Reversing light	● 牵引销	Traction pin	● 钥匙开关	Key switch
● 倒车蜂鸣器	Reversing buzzer	● 照明	Headlamp	● 制动器	Service brake
● 倒车镜	Rearview mirror	● 倾斜可调方向盘	Adjustable steering wheel	● 转向指示灯	Turning signal
● 灯光开关	Light switch	● 倾斜油路自锁	Tilt oil passage self-locking valve	● 随车工具	Toolbox
● 护顶架	Overhead guard	● 全液助力转向	Hydraulic powered steering	● 护灯架	Lamp holder
● 电喇叭	Electric Horn	● 手柄	Handle	● 空档指示	Neutral indicator
● 二片多路阀	2 piece multi valve	● 水温表	Water temperature gauge	● 旋风式空气滤清器	Tornado air filte
● 后尾灯	Rear lamp	● 金属踏板垫	Metal pedal pad		
● 花纹耐用轮胎	Durable pneumatic tire	● 组合仪表	Combined instrument pannel		

选购件 (Options)

○ 前挡风玻璃	Windshield	○ 用户指定颜色	Optional painting
○ 二 (三) 节全自由门架	Two/three stage full-free mast	○ 高排气装置	High exhaust
○ 驾驶室	Cab	○ 减噪净化消声器	Exhaust smoke purification muffler
○ 暖风机	Heater		
○ 灭火消声器	Fire extinguishing muffler		
○ 实心轮胎	Solid tyre		
○ 旋转警示灯	Rotary work alarming light		
○ 小风扇	Mini fan		
○ 文件夹	File clip		
○ 油浴式双空滤 (护顶架)	Oil-bath double filter(on overheadguard)		
○ 灭火器	Fire extinguisher		
○ 倾斜油缸防尘套	Tilt cylinder dust cover		

发动机选配表 (Engine selection table)

型号	额定功率 (kW/r.p.m)	最大扭矩 (N · m/r.p.m)	排量 (L)
-			
朝柴 CY6BG332(6缸)	85/2200	450/1400-1600	5.785
潍柴 WP4.1	85/2300	460/1400-1600	4.09

属具 (Attachment)

● 侧移器	Side shifter
● 调距叉	Fork positioner
● 倾翻叉	Hinged fork
● 串杆	Carpet boom
● 加长货叉	Extended fork
● 加长货叉套	Fork cover
● 起重臂	Lifting boom
● 纸卷夹	Paper roll clamp
● 加宽货叉架	Extended Lift Bracket
● 软包夹	Bale clamp
● 旋转夹	Rotator
● 多用桶夹	Barrel clamp
● 吊钩	Hook